

THIS DRAWING IS UNPUBLISHED. RELEASED FOR PUBLICATION
 (C) COPYRIGHT - By - ALL RIGHTS RESERVED.

REVISIONS					
P	LTR	DESCRIPTION	DATE	DWN	APVD
C		UPDATED DRAWING	09-OCT-18	GL	-

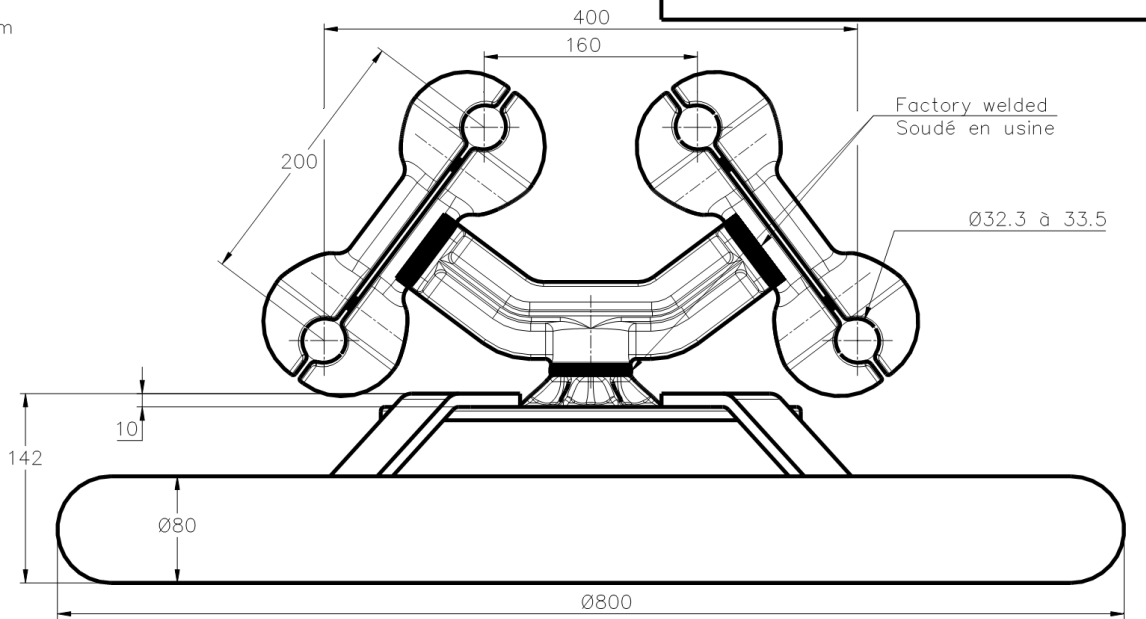
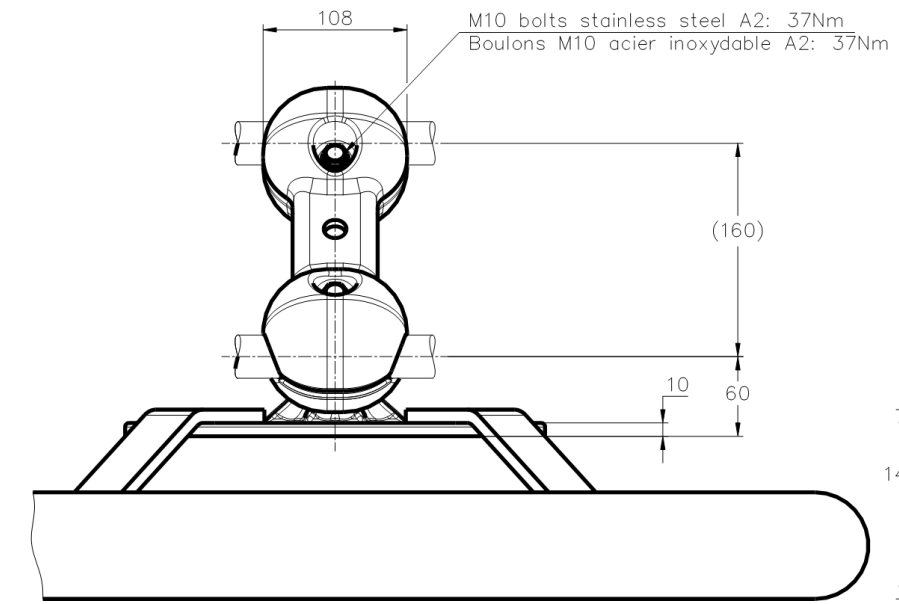
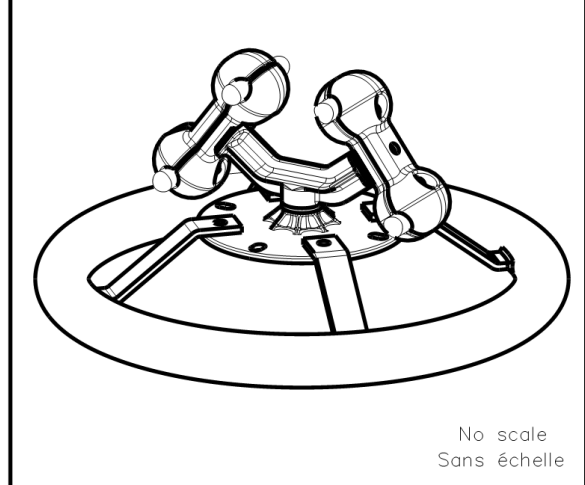
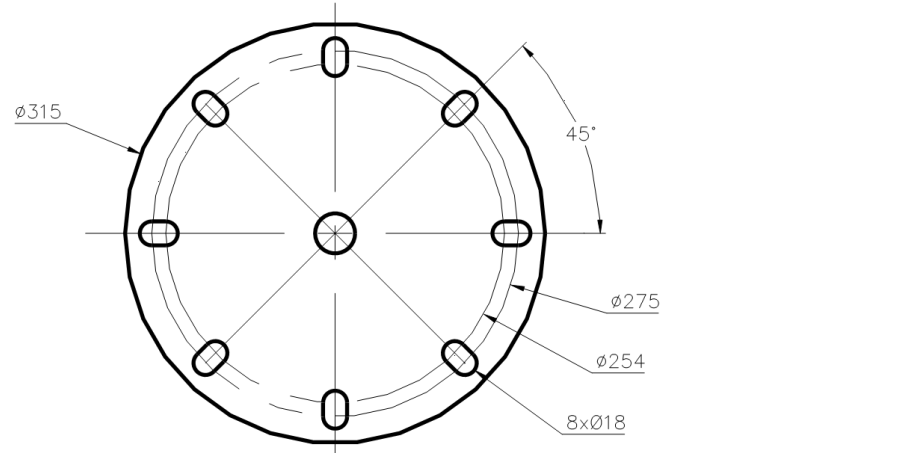

The items shall be assembled on site. The bundle support and the corona shield are supplied separately.

Les articles doivent être assemblés sur site. Le support de câbles et la protection corona sont fournis séparément.

ITEM: 4.10

THIS DRAWING IS A CONTROLLED DOCUMENT.		DWN GODARD	18-Oct-17	STE TE Connectivity																			
DIMENSIONS: mm		CHK -	APVD -			NAME TRAPEZOIDAL BUNDLE SPACER ON BPI SUPPORT DE FAISCEAU TRAPEZOÏDALE SUR ISO																	
TOLERANCES UNLESS OTHERWISE SPECIFIED:		PRODUCT SPEC 02BFC0041		APPLICATION SPEC																			
<table border="1"> <tr><td>0</td><td>PLC</td><td>± -</td></tr> <tr><td>1</td><td>PLC</td><td>± -</td></tr> <tr><td>2</td><td>PLC</td><td>± -</td></tr> <tr><td>3</td><td>PLC</td><td>± -</td></tr> <tr><td>4</td><td>PLC</td><td>± -</td></tr> <tr><td colspan="2">ANGLES</td><td>± -</td></tr> </table>		0	PLC	± -	1	PLC	± -	2	PLC	± -	3	PLC	± -	4	PLC	± -	ANGLES		± -	APPROX. WEIGHT 13.3 kg		SIZE A3	CAGE CODE 00779
0	PLC	± -																					
1	PLC	± -																					
2	PLC	± -																					
3	PLC	± -																					
4	PLC	± -																					
ANGLES		± -																					
MATERIAL -		FINISH -		DRAWING NO C=2326119																			
CUSTOMER DRAWING				RESTRICTED TO -	SCALE 1:4																		
				SHEET 1	REV C																		