

4

3

2

1

THIS DRAWING IS UNPUBLISHED
 DIFFUSION RESTREINTE

RELEASED FOR PUBLICATION
 LIBRE A LA DIFFUSION

2011

ALL RIGHTS RESERVED.
 TOUS DROITS RESERVES

© COPYRIGHT 2011 by Tyco Electronics Corporation

LOC	DIST
-	-

REVISIONS				
P	LTR REV	DESCRIPTION MODIFICATIONS	DATE	DWN DESS APVD APPR
A		CREATION	28-Jul-14	JG -

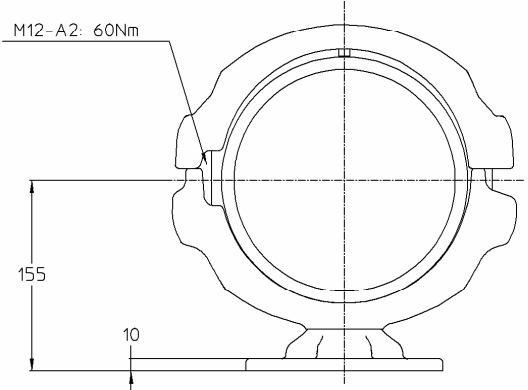
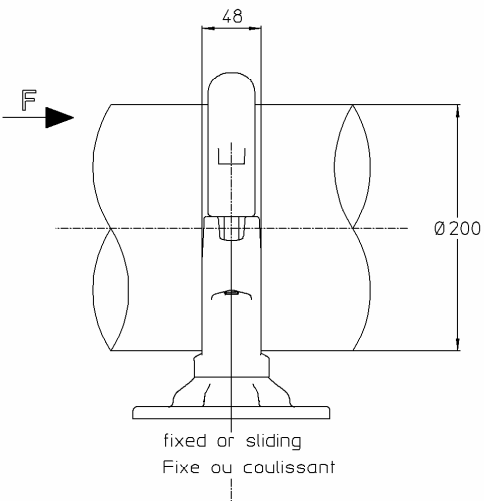
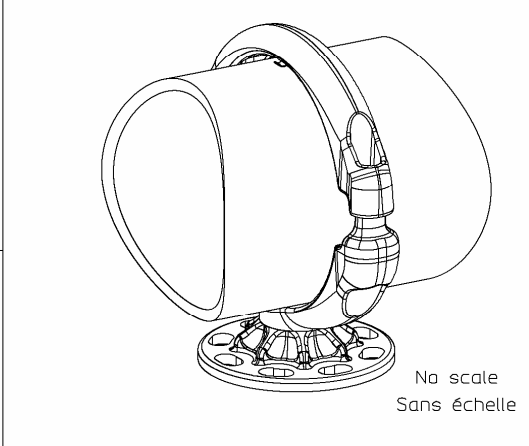
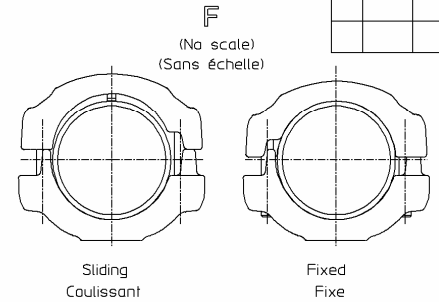
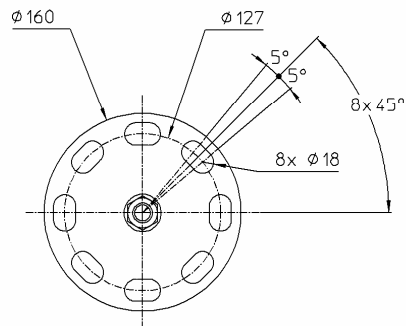

ITEM:

THIS DRAWING IS A CONTROLLED DOCUMENT. <small>LE PLAN EST UN DOCUMENT CONTROLÉ PAR TYCO ELECTRONICS CORPORATION IL EST SUSCEPTIBLE D'ÊTRE REVISÉ POUR OBTENIR LA DERNIÈRE RÉVISION CONTACTER LE SERVICE TECHNIQUE DE TYCO ELECTRONICS SPA, SAS 10200 GENEVY-CHAMBERTIN FRANCE</small>		DWN /DESSINE GODARD	28-Jul-14	TE connectivity SIMEL PRODUCTS					
DIMENSIONS: mm		CHK/VERIFIE -	APVD/APPROUVE -			NAME /TITRE Ø200 BUSBAR SUPPORT ON P5 BPI SUPPORT TUBE Ø200 SUR ISO P5 5 TS 82 P5 T200			
TOLERANCES UNLESS OTHERWISE SPECIFIED PER TOLERANCES NON SPECIFIEES SELON ..		PRODUCT SPEC SPEC PRODUIT 108-62020-001	APPLICATION SPEC SPEC APPLICATION -	SIZE FORMAT A3	CAGE CODE 00779	DRAWING NO No PLAN C=2830563	RESTRICTED TO RESERVE A -		
MATERIAL MATIERE -	FINISH FINITION -	APPROX. WEIGHT MASSE APPROX 2.4 kg	CUSTOMER DRAWING /PLAN CLIENT		UNIQUEMENT POUR REFERENCE	SCALE EHELLE 1/4	SHEET FEUILLE 1	OF DE 1	REV A