

THIS DRAWING IS UNPUBLISHED. RELEASED FOR PUBLICATION
 (C) COPYRIGHT - By - ALL RIGHTS RESERVED.

REVISIONS					
P	LTR	DESCRIPTION	DATE	DWN	APVD
B		UPDATED DRAWING	05-Jan-17	GL	-

Cable Ø18-24

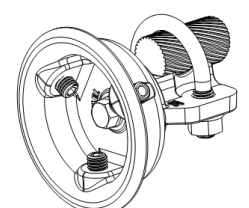

Cable Ø24-35

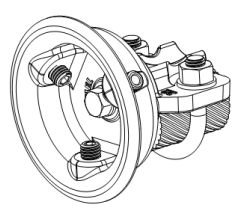

Cable 18DIA to 24 assembly
 Assemblage pour cable Ø18 à 24

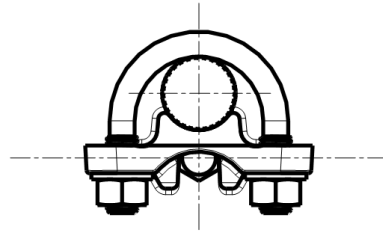

Cable 24DIA to 35 assembly
 Assemblage pour cable Ø24 à 35

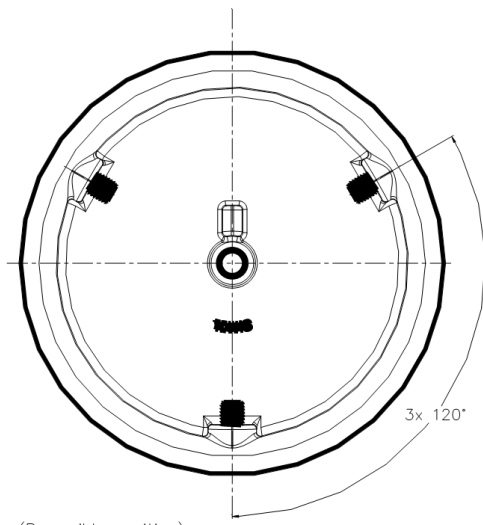
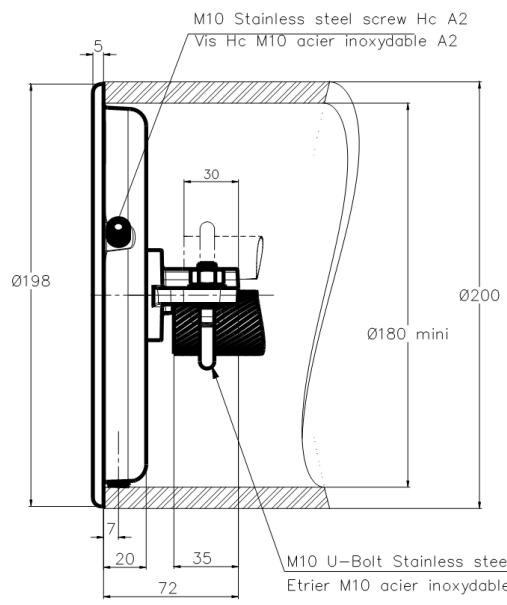
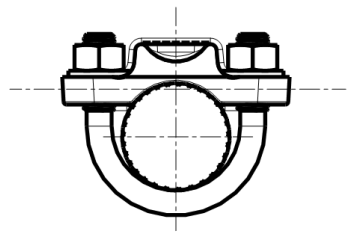

THIS DRAWING IS A CONTROLLED DOCUMENT.		DWN	6-Dec-16	STE TE Connectivity																			
DIMENSIONS: mm		CHK	-																				
TOLERANCES UNLESS OTHERWISE SPECIFIED:		APVD	-	NAME																			
<table border="1"> <tr><td>0</td><td>PLC</td><td>± -</td></tr> <tr><td>1</td><td>PLC</td><td>± -</td></tr> <tr><td>2</td><td>PLC</td><td>± -</td></tr> <tr><td>3</td><td>PLC</td><td>± -</td></tr> <tr><td>4</td><td>PLC</td><td>± -</td></tr> <tr><td></td><td>ANGLES</td><td>± -</td></tr> </table>		0	PLC	± -	1	PLC	± -	2	PLC	± -	3	PLC	± -	4	PLC	± -		ANGLES	± -	PRODUCT SPEC	END CAP CABLE HOLDER		
0	PLC	± -																					
1	PLC	± -																					
2	PLC	± -																					
3	PLC	± -																					
4	PLC	± -																					
	ANGLES	± -																					
MATERIAL		FINISH	108-69090-001	BOUCHON PLAT PORT CABLE																			
-		-	APPLICATION SPEC	5 TABPC 82 T200 18/35 (OPC 200)																			
		WEIGHT	0.775 kg	SIZE	RESTRICTED TO																		
			A3	CAGE CODE																			
			00779	DRAWING NO																			
			C=2301098																				
		CUSTOMER DRAWING	SCALE	SHEET	REV																		
			2/5	1 of 1	B																		

ITEM: C/007-102