

4

3

2

1

THIS DRAWING IS UNPUBLISHED. RELEASED FOR PUBLICATION
 © COPYRIGHT - By - ALL RIGHTS RESERVED.

REVISIONS					
P	LTR	DESCRIPTION	DATE	DWN	APVD
A		CREATION	11-OCT-17	GL	-

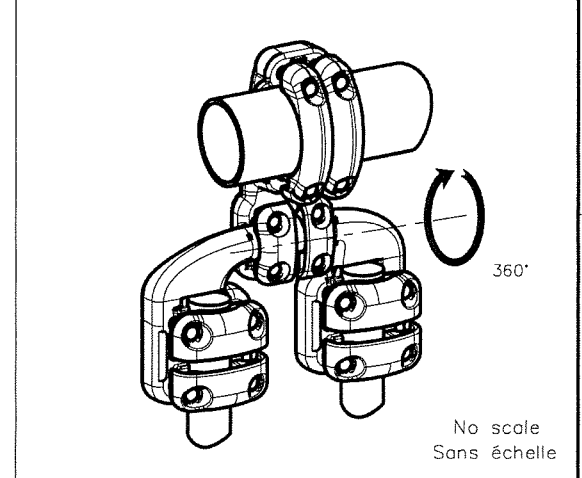
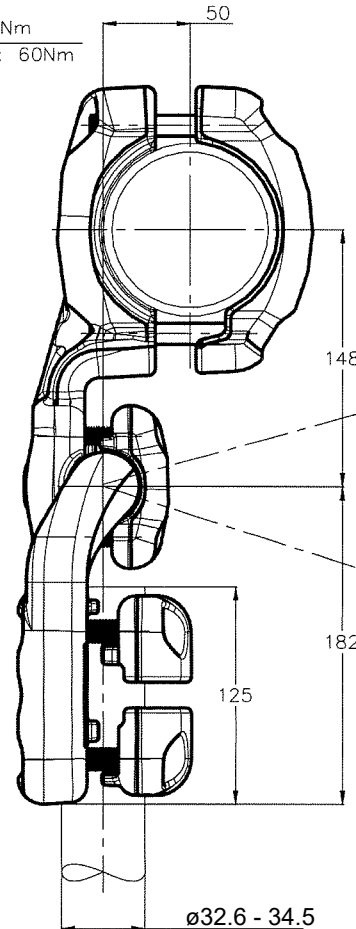
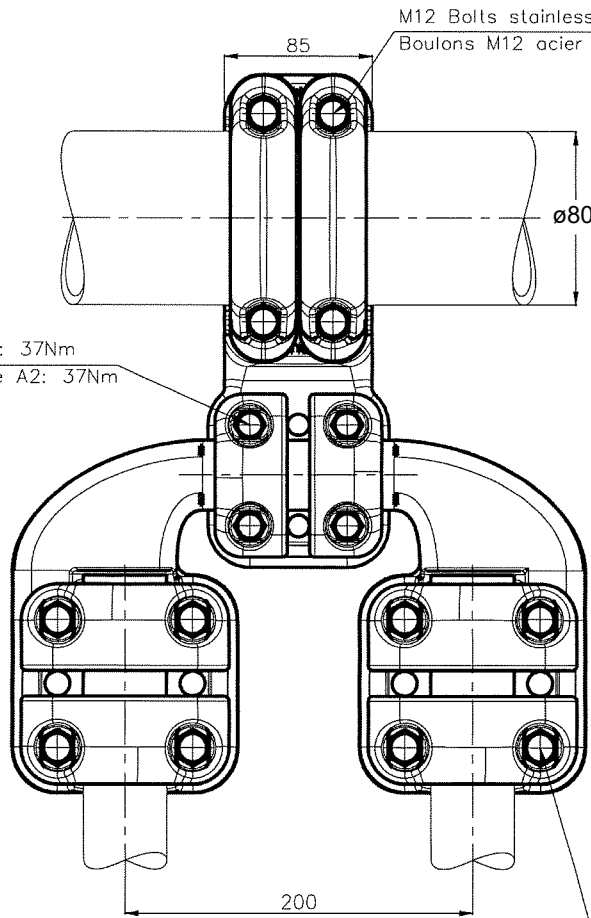

Adjusted on site
 Ajusté sur site

ITEM:.....

THIS DRAWING IS A CONTROLLED DOCUMENT.		DWN LAFORGE	11-OCT-17	STE TE Connectivity	
DIMENSIONS: mm		CHK ---	APVD ---		
TOLERANCES UNLESS OTHERWISE SPECIFIED:		PRODUCT SPEC		NAME ADJUSTABLE TEE CONNECTOR RACCORD EN TE AJUSTABLE	
<ul style="list-style-type: none"> 0 PLC ± - 1 PLC ± - 2 PLC ± - 3 PLC ± - 4 PLC ± - ANGLES ± - 		APPLICATION SPEC 108-69096-001		5 MTA 82 A T80 M345 E200	
MATERIAL		APPROX. WEIGHT 8.36 kg		SIZE A3	CAGE CODE 00779
FINISH		CUSTOMER DRAWING		DRAWING NO	RESTRICTED TO
		SCALE 1:3		SHEET 1 of 1	REV A