

THIS DRAWING IS UNPUBLISHED. RELEASED FOR PUBLICATION  
 © COPYRIGHT - TE Connectivity ALL RIGHTS RESERVED.

| REVISIONS |     |             |           |     |      |
|-----------|-----|-------------|-----------|-----|------|
| P         | LER | DESCRIPTION | DATE      | DMH | APVD |
|           | A   | CREATION    | 08-MAR-18 | BH  | --   |

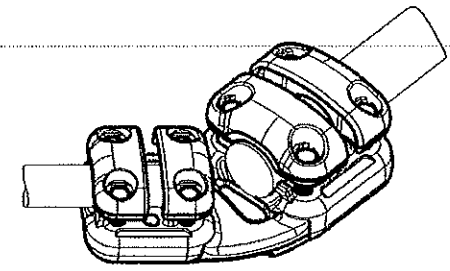

No scale  
 Sans échelle

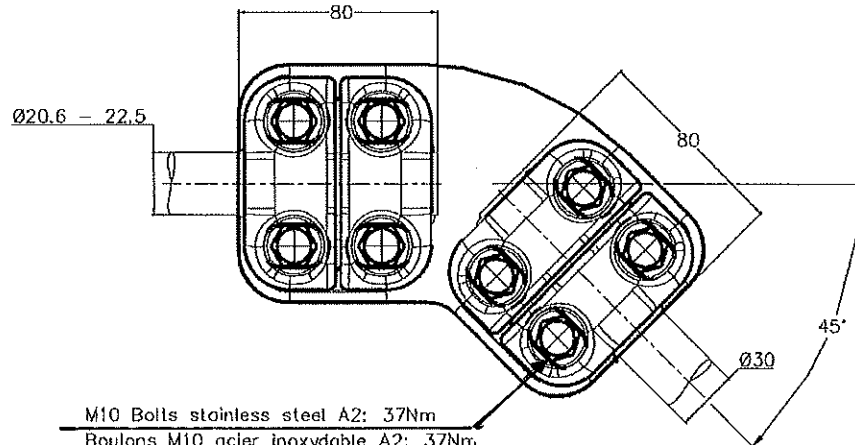

M10 Bolts stainless steel A2: 37Nm  
 Boulons M10 acier inoxydable A2: 37Nm.

ITEM: 5

|  |     |                               |            |                                    |                     |       |     |       |     |       |     |        |     |                        |  |                     |  |
|--|-----|-------------------------------|------------|------------------------------------|---------------------|-------|-----|-------|-----|-------|-----|--------|-----|------------------------|--|---------------------|--|
| THIS DRAWING IS A CONTROLLED DOCUMENT.   |     | DMH<br>HUARD                  | 08-MAR-18  | <b>TE</b> TE Connectivity          |                     |       |     |       |     |       |     |        |     |                        |  |                     |  |
| DIMENSIONS:<br>mm  |     | CHK<br>--                     | APVD<br>-- |                                    |                     | DATE  |     |       |     |       |     |        |     |                        |  |                     |  |
| TOLERANCES UNLESS OTHERWISE SPECIFIED:   |     | PRODUCT SPEC<br>108-69096-001 |            | DRAWING NO<br>5 CJ 45 82 S305 S225 |                     |       |     |       |     |       |     |        |     |                        |  |                     |  |
| <table border="1"> <tr><td>0 PLC</td><td>± -</td></tr> <tr><td>1 PLC</td><td>± -</td></tr> <tr><td>2 PLC</td><td>± -</td></tr> <tr><td>3 PLC</td><td>± -</td></tr> <tr><td>4 PLC</td><td>± -</td></tr> <tr><td>ANGLES</td><td>± -</td></tr> </table> |     | 0 PLC                         | ± -        | 1 PLC                              | ± -                 | 2 PLC | ± - | 3 PLC | ± - | 4 PLC | ± - | ANGLES | ± - | APPLICATION SPEC<br>-- |  | RESTRICTED TO<br>-- |  |
| 0 PLC  | ± - |                               |            |                                    |                     |       |     |       |     |       |     |        |     |                        |  |                     |  |
| 1 PLC  | ± - |                               |            |                                    |                     |       |     |       |     |       |     |        |     |                        |  |                     |  |
| 2 PLC  | ± - |                               |            |                                    |                     |       |     |       |     |       |     |        |     |                        |  |                     |  |
| 3 PLC  | ± - |                               |            |                                    |                     |       |     |       |     |       |     |        |     |                        |  |                     |  |
| 4 PLC  | ± - |                               |            |                                    |                     |       |     |       |     |       |     |        |     |                        |  |                     |  |
| ANGLES   | ± - |                               |            |                                    |                     |       |     |       |     |       |     |        |     |                        |  |                     |  |
| MATERIAL<br>--   |     | WEIGHT<br>1.9 kg              |            | SIZE<br>A3                         | DRAWING NO<br>00779 |       |     |       |     |       |     |        |     |                        |  |                     |  |
| FINISH<br>--   |     | CUSTOMER DRAWING              |            | SCALE<br>1:2                       | SHEET<br>1 of 1     |       |     |       |     |       |     |        |     |                        |  |                     |  |
|  |     |                               |            | REV<br>A                           |                     |       |     |       |     |       |     |        |     |                        |  |                     |  |